

HYTORC XLCT HYDRAULIC TORQUE WRENCH

The XLCT hydraulic wrench with a ring head design is the original model that set the standard for similar tools, and its popularity continues to this day.

- 360° x 270° uni-swivel for easy setup of tool and hoses
- Torque range reaches even 80 000 newton-metres
- Wide range of accessories
- Supplied with a calibration certificate
- Supplied with a carry handle (not in HY-2XLCT)
- Supplied with a robust heavy-duty case

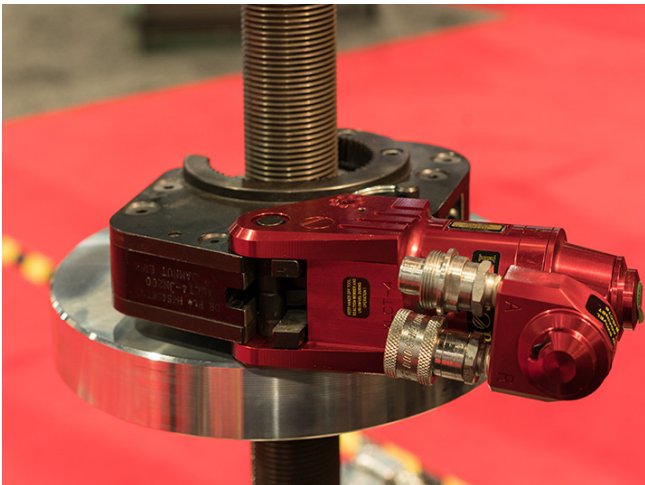

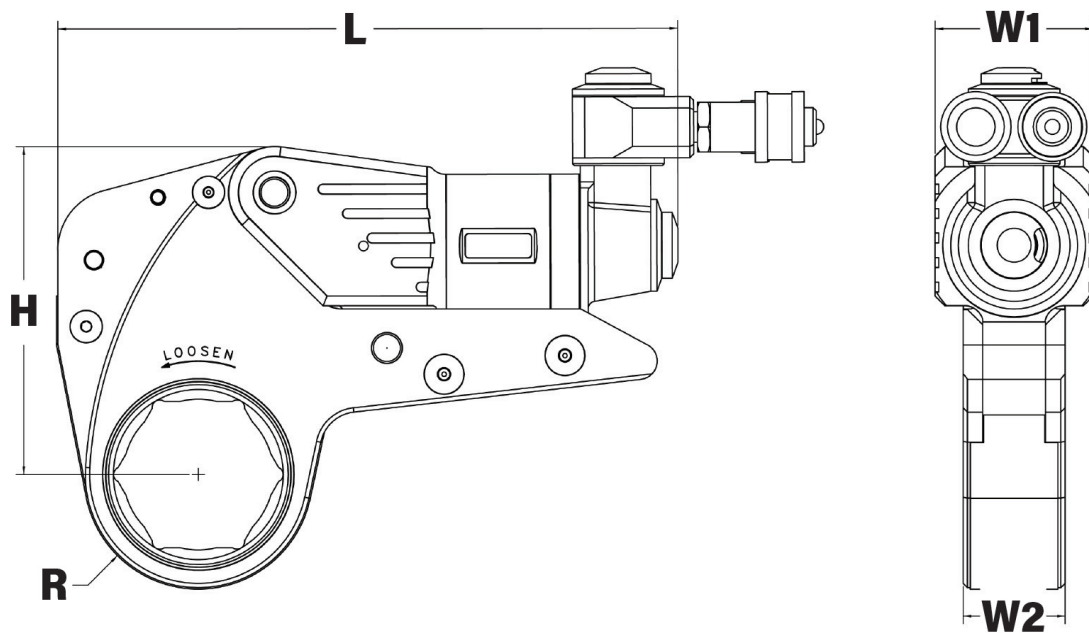

Item	Drive mm	Torque Range Nm	R mm min.	R mm. max.	L mm	H mm	W1 mm	W2 mm	Weight kg
HY-2XLCT	19 - 65	329 - 2 286	26	45	186	102	49	32	0,9
HY-4XLCT	36 - 80	786 - 5 224	34	59	259	136	66	42	1,9
HY-8XLCT	50 - 100	1 549 - 11 045	45	73	312	170	82	53	3,3
HY-14XLCT	70 - 120	2 724 - 18 157	59	88	371	204	99	64	5,1
HY-18XLCT	75 - 145	3 780 - 25 881	67	98	364	231	111	72	6,8
HY-30XLCT	90 - 155	6 205 - 41 986	78	122	427	272	131	85	10,8
HY-45XLCT	100 - 190	9 667 - 66 679	103	124	536	340	152	100	19,5
HY-60XLCT	120 - 190	12 022 - 80 143	122	128	526	340	164	106	21,8

RELEASE LEVER



The XLCT is equipped with a separate release lever, allowing the wrench to be released from the application in case of potential jamming situations.

NON-SLIP RATCHET



The tool contains two latches, one of which prevents the ratchet from turning in the opposite direction during operation.

WIDE RANGE OF ACCESSORIES

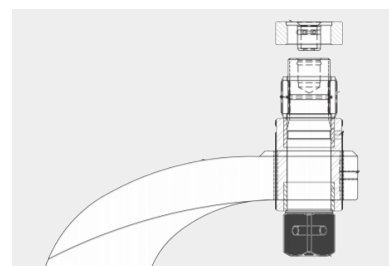

The XLCT models offer a variety of accessories, allowing the wrench to be adapted, for example, into a square drive version.

ACCESSORIES HYDRAULIC TORQUE WRENCHES REACTION ARMS AND SOLUTIONS



1



2



3



4



5



6



7



8



9



10



11



12

Number	Description	Compatibility
1	Square drive type reaction arm	MXT+ / ICE / AVANTI
2	360° x 360° rotatable reaction arm	MXT+ / ICE / AVANTI
3	Standard reaction arm	MXT+ / MXT / EDGE-S
4	Reaction sleeve	MXT+ / MXT / EDGE-S
5	Track pad fixture	MXT+ / ICE / AVANTI
6	Washer driver socket	MXT+ / ICE / AVANTI
7	HYTORC Nut driver	MXT+ / ICE / AVANTI
8	Alco arm	MXT+ / MXT / EDGE-S
9	U-shaped reaction arm	MXT+ / ICE / AVANTI
10	Reaction pad	STEALTH / VERSA / XLCT
11	Alco arm	STEALTH / VERSA / XLCT
12	Welding adapter	MXT+ / ICE / AVANTI

DUAL HYDRAULIC HOSES

- Hose working pressure: 700 bar
- High-visibility color ensures visibility even in poor conditions
- Hose lengths can be customized according to customer specifications, starting from 0.5 m
- All hoses, wrenches, and pumps can be equipped with connectors according to customer requirements
- Standard lengths (m): 5, 6, 8, 10, 12, 16
- Available with protective casing

