

HYTORC STEALTH HYDRAULIC TORQUE WRENCH

A box-head torque wrench designed for confined spaces, featuring a patented dual-piston system that enables a slim-profile body and rapid operation.

- | Easy positioning thanks to a 360° x 180° swiveling connector
- | Compatible with Washer and J-Washer fastening systems
- | Designed for production and maintenance applications
- | Body profile as slim as the box-head attachment
- | Wide range of accessories available
- | Fast and secure quick-lock mechanism for the box-head
- | Includes calibration certificate
- | Removable support handle included
- | Delivered in a carrying case

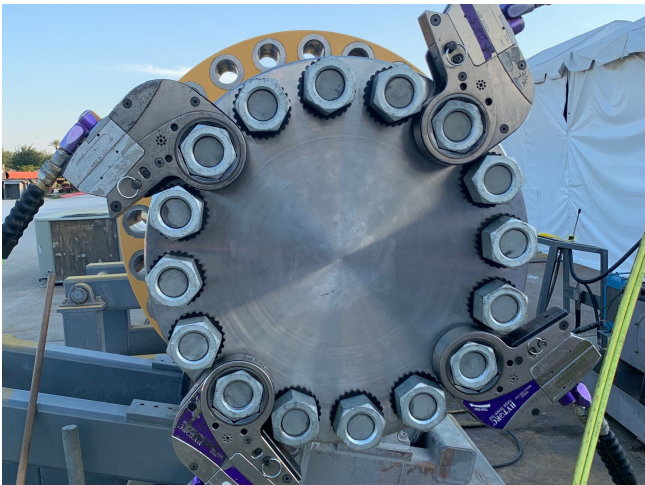

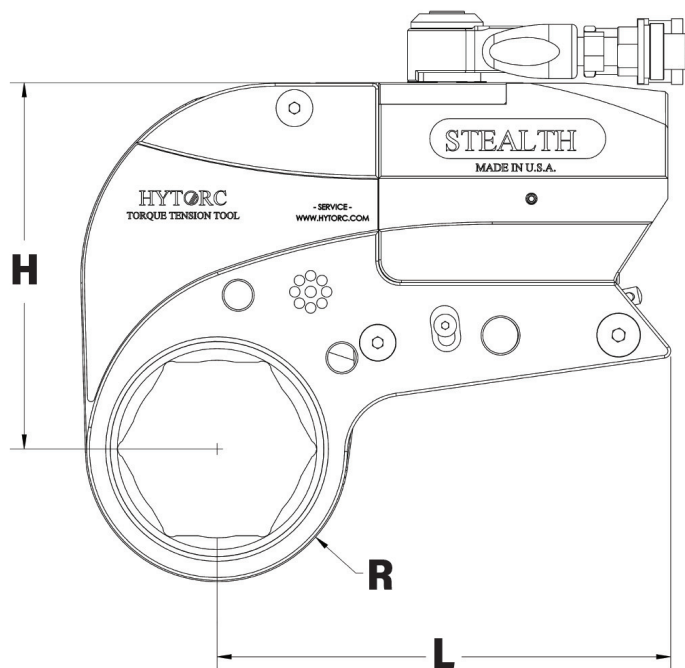
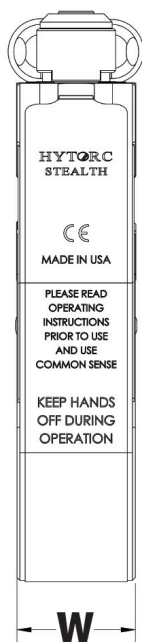

Item	A/F mm	Torque Range Nm	R mm	L mm	H mm	W mm	Weight kg
STEALTH-2	19 - 65	377 - 2 534	26 - 45	140	107	32	2,4
STEALTH-4	27 - 85	819 - 5 450	34 - 59	167	138	42	5,3
STEALTH-8	46 - 105	1 625 - 10 823	45 - 73	203	163	55	9,3
STEALTH-14	55 - 130	2 854 - 19 324	59 - 88	237	202	64	16,6
STEALTH-22	70 - 155	4 406 - 29 654	66 - 98	274	233	74	19,5
STEALTH-36	90 - 175	6 665 - 47 069	78 - 122	323	275	87	31,3

HANDS-FREE OPERATION



The STEALTH tool allows for completely hands-free bolting. The Tool Retainer allows for unparalleled hand safety, attaching the tools to each bolt and eliminating the need to manually hold tools in place.

DUAL-PISTON SYSTEM



HYTORC's patented dual-piston system increases the operating speed of the wrench, making STEALTH the fastest restricted-space torque wrench on the market.

ERGONOMIC AND SLIM DESIGN



The STEALTH® was the first industrial bolting system to feature a continuous slim body design that fits in even the tightest of places. It has a compact, ergonomic design with an integrated reaction pad and a Lock On Release Button. It's easily reversible - simply flip the tool over to change from tightening to loosening.

ACCESSORIES HYDRAULIC TORQUE WRENCHES REACTION ARMS AND SOLUTIONS



1



2



3



4



5



6



7



8



9



10

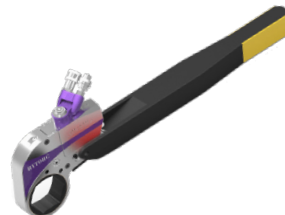

11



12

Number	Description	Compatibility
1	Square drive type reaction arm	MXT+ / ICE / AVANTI
2	360° x 360° rotatable reaction arm	MXT+ / ICE / AVANTI
3	Standard reaction arm	MXT+ / MXT / EDGE-S
4	Reaction sleeve	MXT+ / MXT / EDGE-S
5	Track pad fixture	MXT+ / ICE / AVANTI
6	Washer driver socket	MXT+ / ICE / AVANTI
7	HYTORC Nut driver	MXT+ / ICE / AVANTI
8	Alco arm	MXT+ / MXT / EDGE-S
9	U-shaped reaction arm	MXT+ / ICE / AVANTI
10	Reaction pad	STEALTH / VERSA / XLCT
11	Alco arm	STEALTH / VERSA / XLCT
12	Welding adapter	MXT+ / ICE / AVANTI

DUAL HYDRAULIC HOSES

- Hose working pressure: 700 bar
- High-visibility color ensures visibility even in poor conditions
- Hose lengths can be customized according to customer specifications, starting from 0.5 m
- All hoses, wrenches, and pumps can be equipped with connectors according to customer requirements
- Standard lengths (m): 5, 6, 8, 10, 12, 16
- Available with protective casing

