

## HYTORC MXT+ HYDRAULIC TORQUE TOOLS

**HYTORC MXT+ is the world's first torque wrench to offer a unique hybrid solution, allowing the reaction arm to be positioned either at the rear of the body or on the drive shaft, depending on the requirements of the workpiece.**

- A strong and durable frame construction
- Includes both side axial and rear reaction arms
- A comprehensive range of reaction arms for both coaxial drive and rear reaction
- Integrated tool counter for extended tool life
- Built-in, pump-controlled auto-release mechanism
- 360° x 360° x 360° uni-swivel for easy setup of tool and hoses in even tight places
- Equipped with an easy-to-install cover to prevent damage to the tool's rear splines
- Fully compatible with HYTORC Washers, J-Washers and NUT

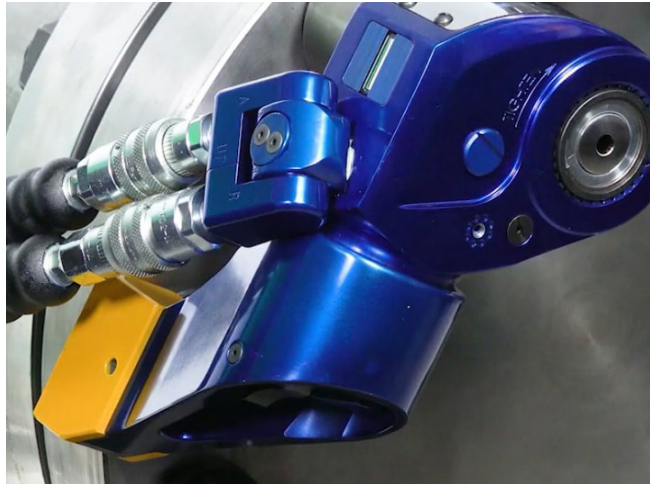

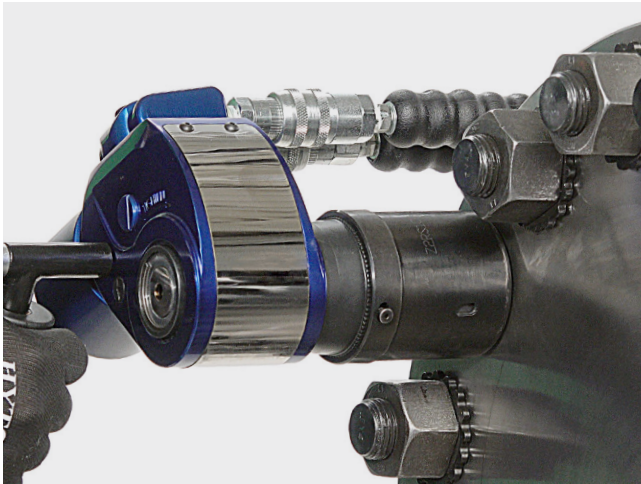
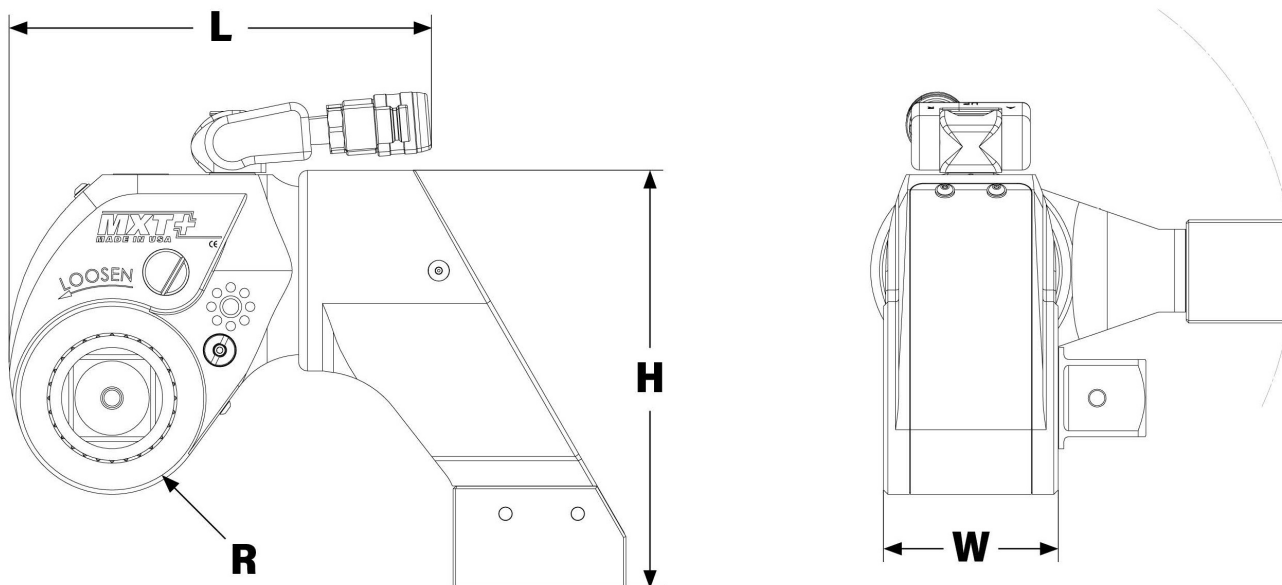

| Item    | Drive  | Torque Range Nm | R mm | L mm | H mm | W mm | Weight kg |
|---------|--------|-----------------|------|------|------|------|-----------|
| MXTP-01 | 3/4"   | 278 - 1 843     | 30   | 131  | 162  | 55   | 3         |
| MXTP-03 | 1"     | 629 - 4 226     | 38   | 169  | 206  | 74   | 6         |
| MXTP-05 | 1 1/2" | 1 101 - 7 351   | 47   | 204  | 235  | 86   | 8         |
| MXTP-10 | 1 1/2" | 2 482 - 16 471  | 60   | 255  | 297  | 110  | 11        |

### AUTO-RELEASE



The MXT+ Wrench has an integrated auto release feature so the operator doesn't have to flip a lever to un-lock the tool from the application. Simply advance the pump and the tool will free itself making bolting operations faster, safer, and simpler.

### EMBEDDED CYCLE-COUNTER



The MXT+ has an embedded cycle counter to monitor tool use and schedule preventative maintenance and calibration. This feature helps maintain the tool at peak performance for accurate and repeatable bolting results. By providing preventative maintenance the user can achieve the longest tool life possible.

### DUAL REACTION



The MXT+ dual-reaction feature allows the user to configure the wrench for rear reaction arms compatible with the original MXT or newer reaction arms compatible with AVANTI and ICE product lines.

## ACCESSORIES HYDRAULIC TORQUE WRENCHES REACTION ARMS AND SOLUTIONS



1



2



3



4



5



6



7



8



9



10

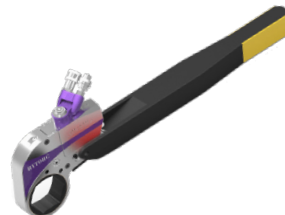

11



12

| Number | Description                        | Compatibility          |
|--------|------------------------------------|------------------------|
| 1      | Square drive type reaction arm     | MXT+ / ICE / AVANTI    |
| 2      | 360° x 360° rotatable reaction arm | MXT+ / ICE / AVANTI    |
| 3      | Standard reaction arm              | MXT+ / MXT / EDGE-S    |
| 4      | Reaction sleeve                    | MXT+ / MXT / EDGE-S    |
| 5      | Track pad fixture                  | MXT+ / ICE / AVANTI    |
| 6      | Washer driver socket               | MXT+ / ICE / AVANTI    |
| 7      | HYTORC Nut driver                  | MXT+ / ICE / AVANTI    |
| 8      | Alco arm                           | MXT+ / MXT / EDGE-S    |
| 9      | U-shaped reaction arm              | MXT+ / ICE / AVANTI    |
| 10     | Reaction pad                       | STEALTH / VERSA / XLCT |
| 11     | Alco arm                           | STEALTH / VERSA / XLCT |
| 12     | Welding adapter                    | MXT+ / ICE / AVANTI    |

## DUAL HYDRAULIC HOSES

- Hose working pressure: 700 bar
- High-visibility color ensures visibility even in poor conditions
- Hose lengths can be customized according to customer specifications, starting from 0.5 m
- All hoses, wrenches, and pumps can be equipped with connectors according to customer requirements
- Standard lengths (m): 5, 6, 8, 10, 12, 16
- Available with protective casing

