

HYTORC GRIP-TIGHT NUT HEAVY VEHICLE WHEEL NUT

HYTORC Grip-Tight Nut is an innovative and safe fastening solution for heavy-duty transportation and other fleet vehicle tire operations.

With this new advanced fastening solution, all heavy vehicle tire changes can now be performed without concerns about excessive lateral forces, unknown friction effects, or inaccuracies caused by them. Designed for use with the Grip-Tight Driver power socket, this solution is compatible with HYTORC's battery and pneumatic high-torque wrenches. The fastening system consists of two parts – the nut itself and an integrated washer system – which together enable an extremely precise and secure clamping connection.

- Significantly increases the efficiency, quality, and safety of heavy vehicle tire changes
- M22 x 1.5 fine thread
- Washer profile allows tightening without additional lateral forces
- The reaction-free power socket is compatible with HYTORC's battery and pneumatic wrenches
- Wheel nuts can also be used with standard impact wrenches or other torque wrenches – however, reaction-free operation is not possible in these cases
- Standard nut dimensions: wrench size 33 mm, height 27 mm, washer diameter 47 mm

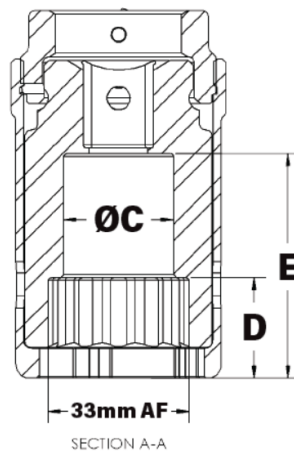
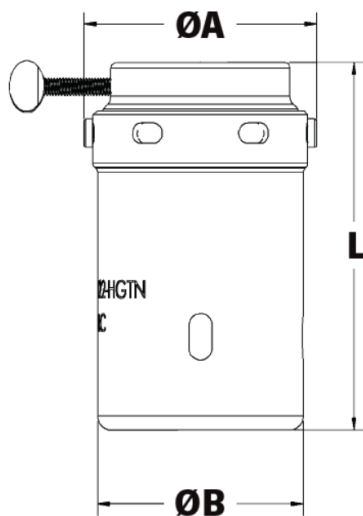

DIMENSIONS

Item	ØA mm	ØB mm	ØC mm	L mm	D mm	E mm	Drive	Weight kg
DZAK-HGTN-M22	63	56	30	100	27	61	19	1,17